

EVO ELECTRIC SCOOTER 500W/800W

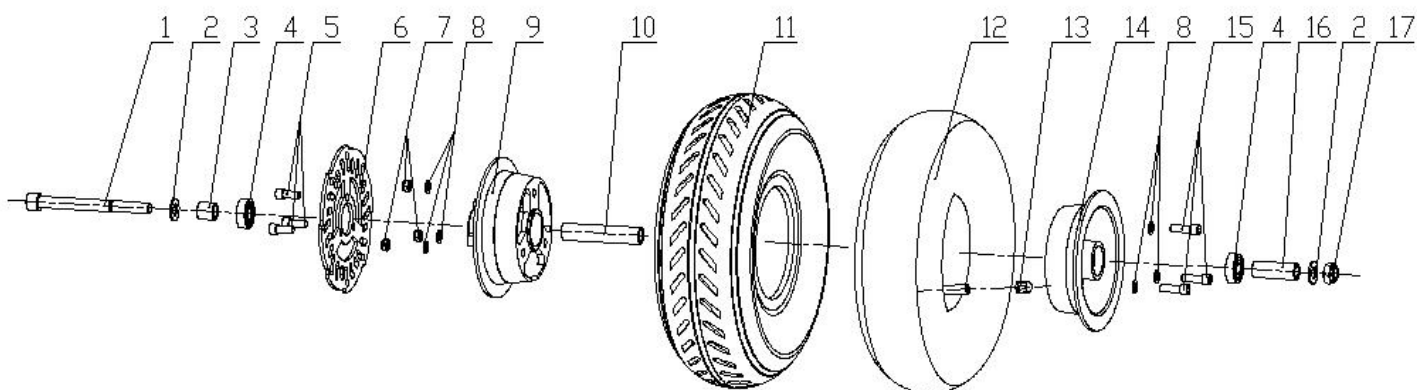

PART-A front wheel



Item	Name	Specification/Size	Qty	Comments
A-1	Bolt	M10×170	1	
A-2	Washer	Φ20×Φ10.5×1.5	2	
A-3	Spacer	Φ15×Φ10.1×15	1	
A-4	Bearing	6000	2	
A-5	bolt	M6×15	3	
A-6	Disk, brake	Φ130	1	
A-7	locknut	M6	3	
A-8	washer	Φ11×Φ6.4×1	3	
A-9	hub, wheel		1	
A-10	spacer	Φ15×Φ10.1×72.8	1	
A-11	tire	10n	1	
A-12	tube		1	
A-13	inflation spot		1	
A-14	Hub, wheel		1	
A-15	bolt	M6×25	3	
A-16	spacer	Φ15×Φ10.1×40	1	
A-17	bolt	M10	1	

PART-B rear wheel

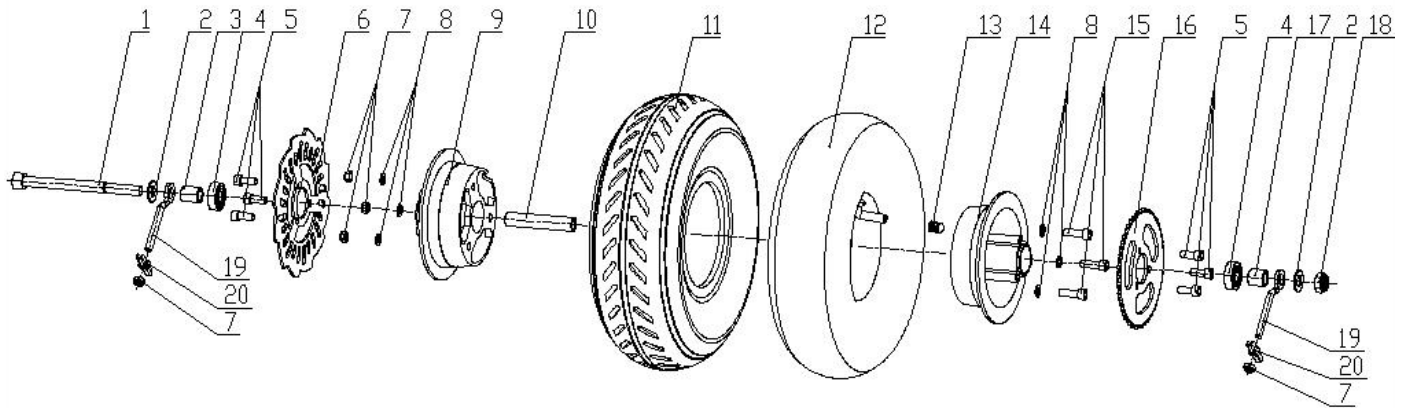

Item	Name	specification/size	QTY	comments
B-1	bolt	M10×170	1	
B-2	washer	Φ20×Φ10.5×1.5	2	
B-3	spacer	Φ15×Φ10.1×17.5	1	
B-4	bearing	6000	2	
B-5	bolt	M6×15	6	
B-6	Disc brake	Φ140	1	
B-7	locknut	M6	5	
B-8	washer	Φ11×Φ6.4×1	6	
B-9	Hub, wheel		1	
B-10	spacer	Φ15×Φ10.1×94.5	1	
B-11	tire	10in	1	
B-12	tube		1	
B-13	Inflation spot		1	
B-14	Hub, wheel		1	
B-15	bolt	M6×25	3	
B-16	Chain sprocket	55th	1	
B-17	spacer	Φ15×Φ10.1×15.5	1	
B-18	Nut, locknut	M10	1	
B-19	Tensioner set		2	
B-20	Tensioner set		2	

PART-C Rear part

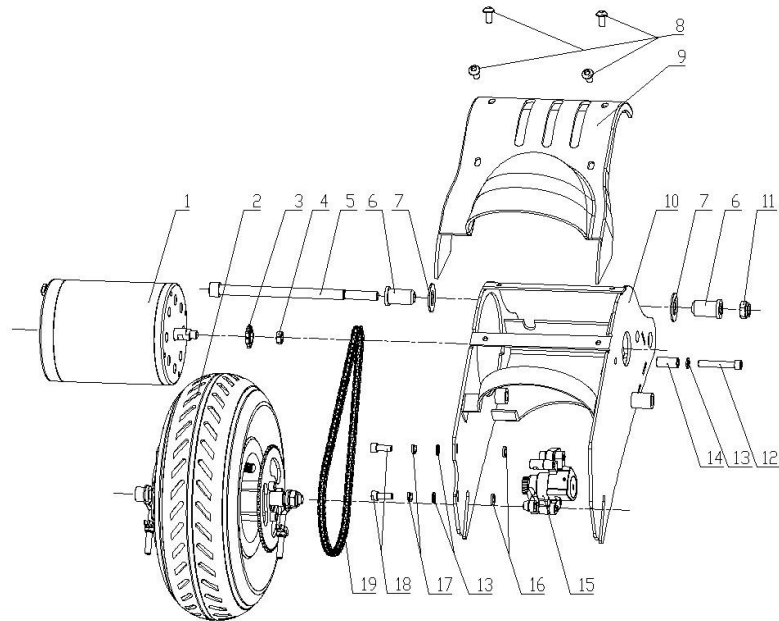

Item	Name	specification/size	QTY	Comments
C-1	motor	800W	1	
C-2	Rear Wheel set		1	
C-3	Small sprocket	11th	1	
C-4	nut	M6	1	
C-5	bolt	M10×170	1	
C-6	spacer	Φ16×Φ10×30	2	
C-7	washer	Φ16×Φ30×1.5	2	
C-8	bolt	M6×12	4	
C-9	mudguard		1	
C-10	frame		1	
C-11	Nut, locknut	M10	1	
C-12	bolt	M6×40	1	
C-13	washer	Φ11×Φ6.4×1	3	
C-14	Spacer for motor	Φ12×Φ7×25	1	
C-15	caliper		1	
C-16	washer	Φ11×Φ6.4×2	2	
C-17	Spring, washer		2	
C-18	bolt	M6×16	2	
C-19	Chain	96kts	1	

D-ES16 Handler Bar

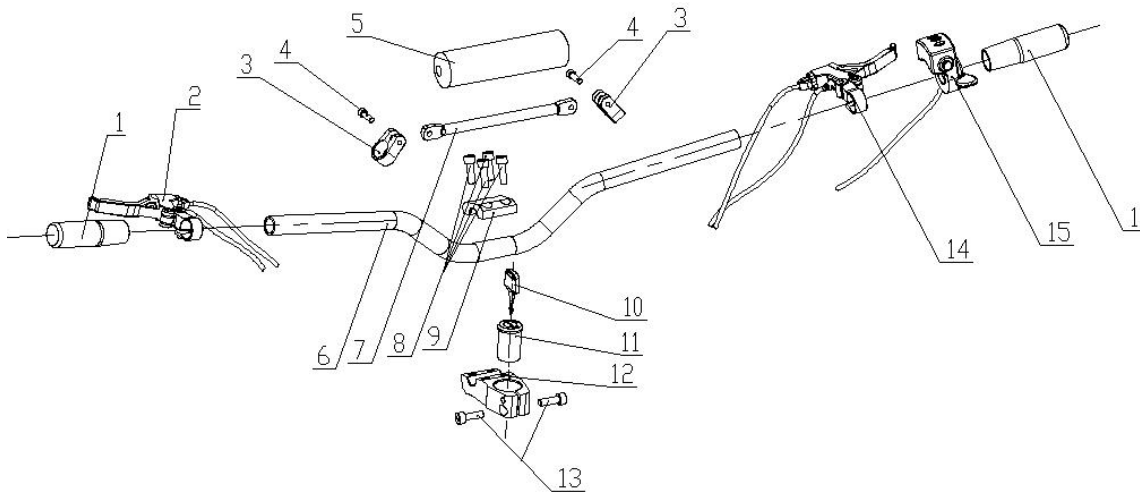

Item	Name	specification/size	QTY	comments
D-1	Grip		2	
D-2	Rear brake lever		1	
D-3	Nut		2	
D-4	Bolt	M6×20	2	
D-5	Spongy sticker		1	
D-6	Handlebar		1	
D-7	Handlebar		1	
D-8	Bolt	M8×20	4	
D-9	Stem, steering		1	
D-10	Key		1	
D-11	Key switch		1	
D-12	Stem, steering		1	
D-13	Bolt	M8×25	2	
D-14	Front brake lever		1	
D-15	Throttle		1	

PART-E front suspension

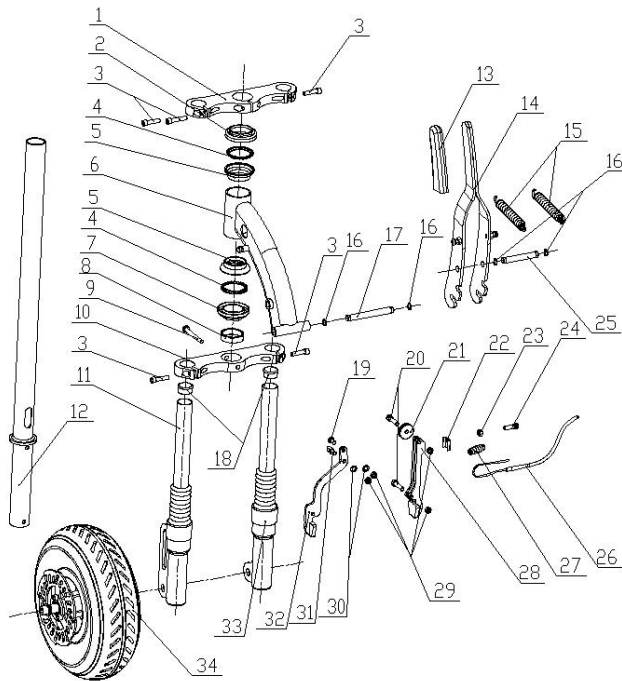

Stem	Name	specification/size	QTY	comments
E-1	connect board up		1	
E-2	Head cup set			
E-3	Bolt	M6×25	5	
E-4	Head cup set		2	
E-5	Head cup set		2	
E-6	Neck tube		1	
E-7	Head cup set		1	
E-8	Head cup set		1	
E-9	Bolt	M6×55	1	
E-10	connect board down		1	
E-11	Front shock, left		1	
E-12	handle pipe		1	
E-13	Grip, folding ,handle		1	
E-14	Folding handle		1	
E-15	Spring		2	
E-16	Clip	Φ10×1	4	
E-17	Pin	Φ10×85	1	
E-18	Shock cover		2	
E-19	Bolt		1	

E-20	Bolt	M6×25	2	
E-21	Pulley		1	
E-22	Washer		1	
E-23	Nut	M6	1	
E-24	Bolt	M6×17	1	
E-25	Pin	Φ10×65	1	
E-26	Brake cable		1	
E-27	Spring		1	
E-28	Brake pad		1	
E-29	Locknut	M6	4	
E-30	Washer	Φ11×Φ6.4×2	2	
E-31	Bolt		1	
E-32	Brake pad		1	
E-33	Front shock, right		1	
E-34	Front wheel set		1	

PART-F Frame

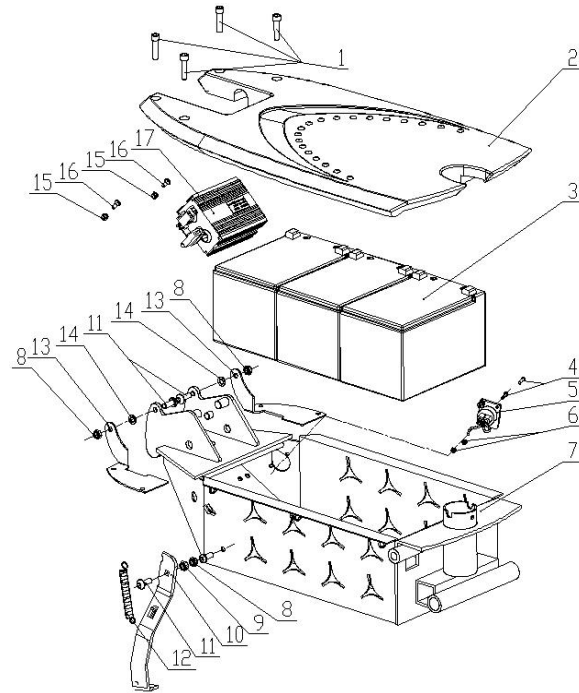

Item	Name	specification/size	QTY	comments
F-1	Bolt	M6×25	4	
F-2	Foot deck		1	
F-3	Battery	12V/12Ah	3	
F-4	Bolt	M3×13	2	
F-5	Charger spot		1	
F-6	Nut	M3	2	
F-7	Battery box		1	
F-8	locknut	M6	1	
F-9	nut	M6	1	
F-10	Kick stand		1	
F-11	bolt	M6×16	3	
F-12	spring		1	
F-13	Left/right connect		2	
F-14	washer	Φ11×Φ6.4×1	2	
F-15	locknut	M4	2	
F-16	bolt	M4×10	2	
F-17	controller	30A/800W	1	

PART-G Rear shock

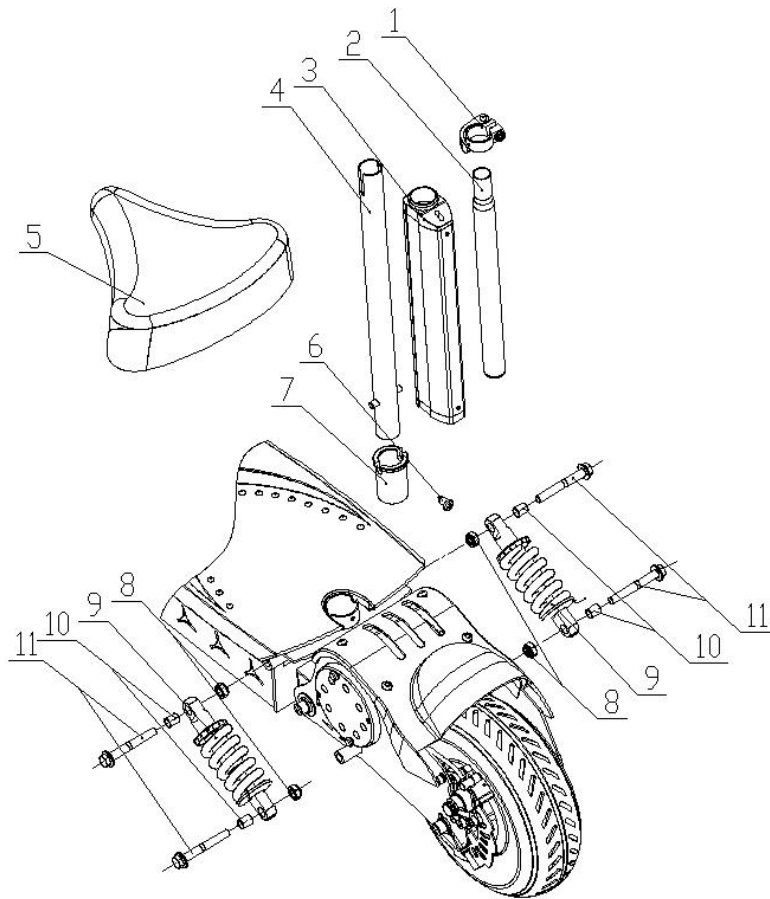

Item	Name	specification/size	QTY	comments
G-1	Seat clip		1	
G-2	Seat pole		1	
G-3	Seat pole, cover		1	
G-4	Seat pole		1	
G-5	Seat		1	
G-6	Bolt	M3×6	1	
G-7	Seat bush		1	
G-8	Locknut	M10	4	
G-9	Rear shock		2	
G-10	Spacer	Φ12×Φ10×14	4	
G-11	Bolt	M10×70	4	